



自行车箱
BIKE.CASES & BAGS



PHOTO: ©chalabala / Fotolia.com



新款自行车箱上市: **BIKE.CASE II**

适用于29"自行车的创新运输解决方案
The innovative transport solution for bikes up to 29"



倍威实业(嘉兴)有限公司

浙江省嘉兴市经济技术开发区丰华路997号 电话: +86 573 8269 3229 传真: +86 573 8269 3530
邮箱: info@b-w-international.com.cn 网址: www.b-w-international.com.cn

自行车箱-您旅行的伙伴

TRAVEL COMPANION

对于一个骑行者而言，骑着自己的自行车旅行或者训练是一件非常重要的事情，尤其是在假期。骑车到您的极限或者在温暖的国度训练都能使您的自行车旅行变得完美。然而，如何运送您的自行车并使其不受损坏这一点一直被大家忽视。

值得庆幸的是，来自B&W设计生产的巧妙创新的自行车箱产品可以在旅途中完美保护您的自行车。

所有亲眼见过箱子是如何在飞机上装载和卸载的人，都知道在这过程中箱子遭受着怎样的对待。而B&W仔细的考虑到了这一点。

我们的箱子拥有加固的护角，平稳运转的轮子和可调整的捆绑带，使您的自行车得到安全的保护。

Riding and training on your own bicycle is an absolute highlight for any cyclist, especially during the holiday. Riding to your limits or training in warm countries are just two of many things that make a good cycling trip. However, an absolute requirement is the ability to transport your bicycle without it being damaged.

This is one thing you can rely on thanks to the clever innovations produced by B&W International. Our **bike.cases** & bags protect your bicycle during the flight.

Whoever has seen how cases are handled when they are being loaded and unloaded onto an aircraft knows the treatment to which they are exposed and we at B&W International take that into careful consideration.

Our cases have stable case shapes, rigid materials, reinforced smooth-running wheels and integrated tension belts to guarantee that your bicycle will be safe and secure.



带着您的自行车上飞机

为什么要带着您自己的自行车？

所有骑行者都有这样的经验：骑着自己的自行车更好更安全，因为您熟悉它的装备、座位的高低及舒适度，您也更了解刹车和齿轮处于怎样的状态。

自行车箱内富余的空间可以放置您的头盔、鞋子、工具、背包等物品。但是，箱子的总重量不能超过30KG。

旅行前

- 预定航班前请查询此航班是否允许托运装有自行车的自行车箱，以及费用是多少。
- 预定航班时，请告诉旅行社您将携带您的自行车。这个信息将传输到航空公司，并且，您后续将收到另外的通知。
- 费用与航空公司相关。如果您未受到另外的通知，这部分费用经常是直接登机手续办理处直接支付的。
- 同时，请考虑好如何将自行车箱从机场运送到酒店。如果您的旅行是旅行社全程负责的，那么请在预定的时候告诉旅行社，自行车箱需要从机场运送到酒店并运回。否则会产生额外的费用。
- 自行车大赛组织者：自行车的运输一般都包含在旅行费用中了，在出发前合适的时间会通知您。

出发

- 当您决定带着自行车出行，请保证充足的时间来办理登机手续。
- 如果您的出发时间为凌晨，我们建议您在前一晚做好登机准备，以此节约出发当天的时间。
- 和往常一样到登记台办理登机手续。当您拿到登机牌之后，您应该去另外一个柜台办理大件行李托运。

到达目的地机场

自行车箱通常是抵达在特殊的行李传输带上，或者是通过一个大件行李的门交到您手上。自行车箱很少出现在普通的行李传输带上。

箱子受损

如果发现箱子有破损，请立即通知航空公司。在大多数的机场，失物招领处一般都能帮到您。

AIRLINE TRAVEL WITH YOUR BIKE

Reasons for taking your own bike:

All cyclists know from their own experience: you ride your own bike much better and safer because you know your equipment, the seat position is right and you are thoroughly familiar with the brakes and the gears and you know the condition they are in. Available space in the case can be used to store your helmet, shoes, tools and bike backpack etc. Please note that the overall weight of the bike case should not exceed 30 kg.

BEFORE TRAVELLING

- Find out before booking whether the airline carries sport luggage (bike in the case) and how much the charges are.
- Notify the travel agency directly when booking that you want to take your own bike. This information will be passed on to the airline and you will receive separate notification.
- There are costs associated with registering with the airline. If you don't receive any other notification, these costs are usually paid directly at the check-in desk.
- Also think about transport from the airport to the hotel. For package travel deals: notify the travel agency about bike transport from the airport to the booked hotel and back when booking, otherwise additional costs may be incurred.
- Cycling event organisers: transport is frequently included in the travel cost. Inform yourself in good time before departure.

DEPARTURE

- You should generally plan more time to check-in when you travel with a bike.
- For early morning departures, we recommend the late night check-in service to save time on the day of departure.
- Report to the check-in desk as usual. Once you have received your boarding card, you usually have to go to a separate desk for bulky luggage.

AT THE DESTINATION AIRPORT

The bike case usually arrives on a special conveyor belt or is handed to you through a door for bulky luggage. It is rare for it to arrive on the normal suitcase conveyor belt.

DAMAGES TO THE CASE

Report any damages to the case immediately to the airline. The "Lost & Found" desk usually helps you at most airports.



BIKE.CASES & BAGS

以下箱子适用于您的自行车类型

THE FOLLOWING CASES ARE SUITABLE FOR YOUR BIKE TYPE



	bike.guard curv®	bike.box II	bike.case II	bike.box	bike.bag II
--	------------------	-------------	--------------	----------	-------------

公路自行车和铁人三项自行车 ROAD and TRI-BIKES	bike.guard curv®	bike.box II	bike.case II	bike.box	bike.bag II
-自行车车架尺寸62cm及以下的 - up to frame size 62 cm	●	●	●	●	●
-自行车车架尺寸大于62cm的 - frame size >62 cm	●		●		
-带有综合坐杆的 - with integrated seat post	●		●		
山地自行车 MOUNTAINBIKES					
-前避震自行车 - Hardtail	●	● 车架尺寸46cm及以下的 up to frame size 46 cm	●	●	●
-全避震自行车 - Fullsuspension	●		●	● 车架尺寸44cm及以下的 up to frame size 44 cm	●
-速降自行车 - Downhill Bike			●		●
旅行自行车 TREKKING BIKES					
			●		●

	bike.guard curv®	bike.box II	bike.case II	bike.box	bike.bag II
运输推荐方式 recommended method of travel	航空运输、货运 air travel, freight	航空运输、货运 air travel, freight	航空运输、货运 air travel, freight	航空运输、货运 air travel, freight	航空、汽车、铁路运输 air travel, travel by car, rail travel
外尺寸(mm) external dimensions (mm)	1310 x 910 x 315	1190 x 890 x 295	1345 x 880 x 350	1140/850x885x295	1360 x 854 x 297
内尺寸(mm) internal dimensions (mm)	1300/1070 x 840 x 285	1150/825 x 810 x 280	1300 x 815 x 320	1080/780x800x250	
包装尺寸(mm) packing dimensions (mm)	1340 x 930 x 210	1200 x 920 x 200	1355 x 860 x 335	1160 x 900 x 300	
重量 (包含配件) weight (kg)	10.9	11.7	16	16.5	
最大载重量 max. load(kg)	15	15	20	20	

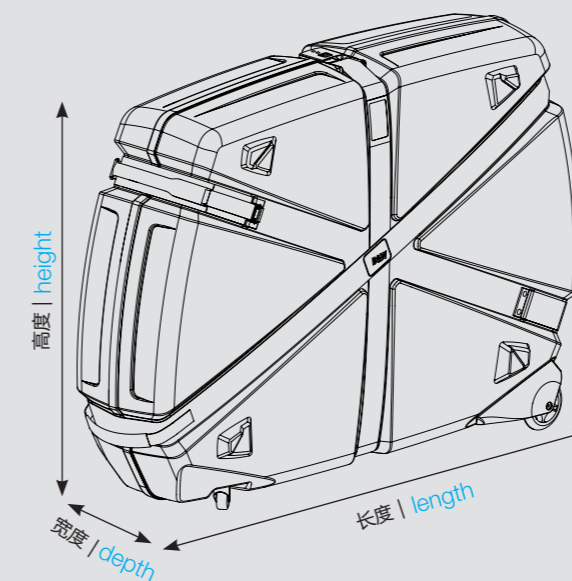

注意：尺寸是基于闭合并且直立的自行车箱或自行车包的长度X宽度X高度。这个表格中的信息仅供参考。具体需要哪款箱子，请根据自行车的实际尺寸对照箱子的内尺寸来选择。如果需要的话，自行车的后变速器都要拆掉。如果你需要了解更多细节，请登录我们的网址：

<http://www.b-w-international.com.cn/products/bike-cases/>

请注意自行车包bike bag跟bike guard Curv®、梯形自行车箱和矩形自行车箱比较而言，只是对下面部分提供了保护，上面部分对压力和冲击的抵抗仍是脆弱的。

Note: The dimensions stated are length x height x depth for a closed upright case or closed upright bag. This table only serves the purpose of providing initial orientation. For the actual possibilities of use, please compare the interior dimensions with the dimensions of the dismantled wheel from the front edge of the fork drop to the end of the rear derailleurs and the height of the seat post to the underside of the chain wheel. If necessary, the rear derailleurs must be dismantled. Therefore you should measure the front edge of the fork drop to the back edge of the frame drop. If you want to know in more detail if your bike fits, make use of our configurator on our website:

<http://www.b-w-international.com/product-category/bike-cases/>

Please note that the bike.bag only offers protection in the lower section in contrast to the bike.guard curv®, the bike.box II and the bike.case II. The top section remains fragile to pressure and impacts.

自行车箱 BIKE.CASES

8.2 kg
weight without accessories
不含配件重量

bike.guard curv®

特性 | FEATURES

- 世界上最轻的自行车硬箱，自重8.2KG。
- 适用于公路自行车、山地自行车和铁人三项自行车，配有29"轮胎包。
- 高度耐冲击、耐磨损、坚固、耐用。
- 2个万向轮，2个定向轮。
- 4个拎手：1个可调节的拎手，1个可推动2个轮子的拎手，2个可以拎的拎手。
- 为了简化包装，上盖可以完全拿掉。
- 箱子的底和盖有6个点可以互锁，通过2个铁扣很容易就能将箱子关上。
- world's lightest full-sized, hard bike case at 8.2 kg (without accessories)
- made of self-reinforced Curv®-material suitable for road bikes, mountain bikes and triathlon bikes, with 29" wheel guards
- highly impact resistant, abrasion resistant, tough and durable
- four easy-rolling wheels, two which freely rotate and two fixed
- four handles: one adjustable pulling handle, one pulling handle to pull on two wheels, two handles to carry
- for simplified packing, the top shell can be removed completely
- the two case halves are interlocking at six points around the side, and pulled together with two self-tightening buckles for easy closing and fitting of the case
- lockable with a TSA padlock (not included in the delivery)



规格 | SPECIFICATIONS

内尺寸: 1300(底)/1070(盖)x840x300mm

外尺寸: 1310x910x315mm

净重: 8.2kg | 颜色: 黑色 | 材质: 自增强的PP

internal dimensions 1300 (bottom)/1070(top) x 840 x 300mm

external dimensions 1310 x 910 x 315mm

weight (net) 8.2kg | color black | material self reinforced PP

款号 | ITEM-NO. 96015



能如此迅速和便捷的将自行车储存在这些箱子里面令人印象深刻。感谢这些箱子，让我们的自行车在运输途中不会再有损坏。

It is still impressive how quick and easy you can store the bikes in these cases. Thank to the cases we do not have any more damage in transit!

Fabian Brintrup - rad-net ROSE Team



铁扣
self-tightening buckle



可配TSA海关锁
lockable with TSA padlock

bike box II

NEW!



特性 | FEATURES

- 适用于车架尺寸62cm及以下的公路自行车和更小的山地自行车。
 - 为了简化包装，上盖可以完全拆除。自行车由几根织带固定，并且由几块海绵块作保护。
 - 2个万向轮，2个定向轮。
 - 2个拎手，2个拉手（其中一个拉手可推动轮子）。
 - 箱子的底和盖由6个点可以互锁，通过2个铁扣可以很容易就能将箱子组装和关上。
 - 可用TSA海关锁（不包含在产品内）。
- suitable for road bikes up to 62cm frame size and smaller mountainbikes
 - for simplified packing the top shell can be completely removed
 - the bike is mounted with several straps and protected by several layers of foam
 - four stable light castors, two freely rotatable, two fixed
 - two carrying handles and two pull handles (one pull handle for pulling on two wheels)
 - the two case shells are interlocking at six points and pulled together with a self-tightening buckle for easy closing and fitting of the case
 - lockable with a TSA padlock (not included in the delivery)

规格 | SPECIFICATIONS

内尺寸: 1150 (底) /825 (盖) x810x280mm
外尺寸: 1190x890x295mm
重量: 10.6kg | 颜色: 黑色 | 材质: ABS

internal dimensions 1150 (bottom)/825(top) x 810 x 280mm
external dimensions 1190 x 890 x 295mm
weight 10.6kg | color black | material ABS

款号 | ITEM-NO. 96500



拉手和拎手 (黑色)
pull handle & carrying handle (black)



稳固的轮子
robust wheels



铁扣
self-tightening buckle

Stölting Service Group团队为使用B&W的自行车箱和自行车包而感到骄傲。因为它们能保护骑行者和员工的自行车等装备在骑行前后的运输过程中完好无损。有了这些自行车包和自行车箱，团队能确信他们的自行车、配件、机械工具能够得到很好的保护，因此能更加专注比赛从而赢得胜利。

Team Stölting Service Group is proud to use B&W bike.cases & bags to help facilitate the transportation of equipment for both riders and staff – equipment that the team needs to be in perfect condition both before and after travel. With its bags and cases, the team can be confident that their bikes, kit and mechanical tools are well looked after, leaving them to concentrate on racing and striving for victory.

Stölting Service Group Team



bike.case II

NEW!



特性 | FEATURES

- 运输赛车、铁人三项车和山地自行车（包括29"）的大型保护箱
- 带有铝框和嵌条
- 上盖可以完全拆下来
- 包含2个29" 的轮胎包
- 4个灵活便捷的轮子，2个万向轮和2个定向轮
- 2个拎手和2个拉手（其中1个拉手可推动轮子）
- 可用TSA挂锁锁住箱子（不包含在产品内）
- big protective case for the transport of racing bikes, triathlon bikes and mountain bikes up to 29"
- surrounding aluminum frame and protection ring
- for simplified packing the top shell can be completely removed
- incl. two 29" wheel guards
- four easy-rolling wheels, two which freely 360° rotate and two fixed
- two carrying handles and two pull handles (one pull handle for pulling on two wheels)
- lockable with a TSA padlock (not included in the delivery)

规格 | SPECIFICATIONS

内尺寸: 1300 x 815 x 320 mm | 外尺寸: 1345 x 880 x 350 mm

净重: 16kg | 颜色: 黑色 | 材质: ABS

internal dimensions 1300 x 815 x 320 mm

external dimensions 1345 x 880 x 350 mm | weight 16kg

color black | material ABS

款号 | ITEM-NO. 96600



稳固的轮子
robust wheels



可拆卸的上盖
removable lid

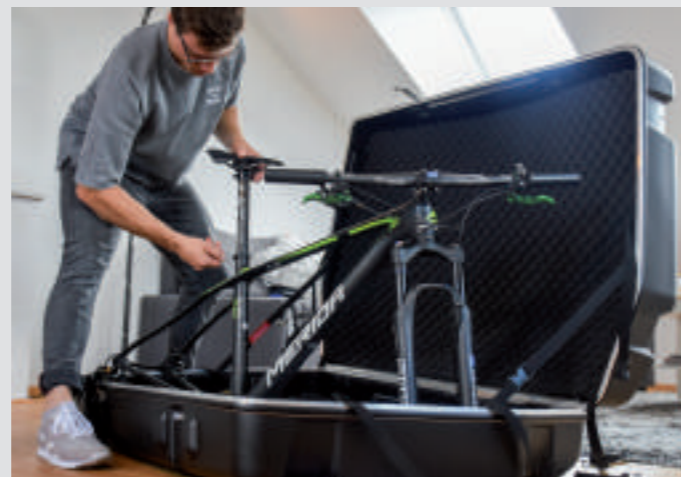

Simon Gutmann说：“我们真的可以依赖这款自行车箱。当我们到达目的地，发现我们的自行车没有一点划伤。自行车打包非常简单，而且灵活的轮子、拎手和拉手，让我们带着自行车箱旅行也变得简单。”

"We really can rely on the bike cases. When we reach our destination, we find our bikes without a scratch", says Simon Gutmann. "It is quite easy to pack the bikes, and due to the smooth-running wheels and the pulling & carrying handles, it is even very easy to travel with the bike case."

Team Freiburger Pilsener Merida



自行车箱 BIKE.CASES

bike box

特性 | FEATURES

- 适用于公路自行车和山地自行车
 - 带有十分坚固的铝框架和嵌条
 - 海绵块可保护后链轮齿
 - 2个28" 轮胎包
 - 加固的轮轴和4个灵活的轮子
 - 两个万向轮、两个定向轮
 - 2个拎手和1个加固的手把
 - 箱内有插扣带
 - 前叉保护海绵管
 - 固定手把海绵带
 - 链条保护包
- trapezoidal bike case, suitable for road and mountain bikes
 - surrounding aluminum frame and protection ring
 - foam block to protect the rear sprocket
 - incl. two 28" wheel guards
 - four free running castor wheels with reinforced axle
 - two carrying handles and a reinforced pilot handle for easy handling
 - outward belt embedded in the case shell



规格 | SPECIFICATIONS

内尺寸: 1080(底)/780(盖)x800x250mm
外尺寸: 1140(底)/850(盖)x885x295mm
净重: 10kg | 颜色: 黑色 | 材质: ABS

internal dimensions 1080 (bottom)/780(top)x800x250mm
external dimensions 1140 (bottom)850(top)x885x295mm
weight (net) 10kg | color black | material ABS

款号 | ITEM-NO. 96910/N

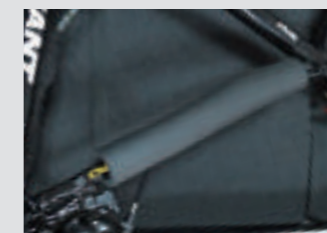

bike.bag II

NEW!



特性 | FEATURES

- 自行车包和自行车箱的结合体，上部分是防撕裂的涤纶面料，底是ABS材质
- 用于运输公路自行车、铁人三项自行车和山地自行车（包括29"）
- 4个灵活的轮子，其中2个是万向轮
- 拎手带和手把
- 2个29" 轮胎包
- 高品质双向拉链
- combination of bag and case: bottom made of ABS merges into a bag made of padded ripstop polyester
- suitable for the transport of racing bikes, triathlon bikes and mountain bikes incl. 29"
- four easy-rolling wheels, two which freely 360° rotate and two fixed
- different carrier straps and pilot handles
- high-quality 2-way-zipper

规格 | SPECIFICATIONS

外尺寸: 1360 x 854 x 297 mm

材质: ABS+仿尼龙

external dimensions 1360 x 854 x 297 mm

material ABS + ripstop polyester

款号 | ITEM-NO. 96900



作为专业街攀车手的邓肯·肖来说，从格拉斯哥、布里斯托尔到阿姆斯特丹再到加利福尼亚州，骑自行车旅行是邓肯·肖日常工作的一部分。“倍威的产品系列涵盖了街头骑行者的所有需求。如果你正在寻找可方便安全的运送装备的高品质的箱子，那么倍威就是你的正确选择。我会强烈推荐倍威的箱包给我所有的伙伴。”

From Glasgow, Bristol and Amsterdam to California - as a street trials professional, traveling with his bike is part of Duncan Shaw's daily work. „B&W International's product range covers all the needs of a travelling street trials driver. B&W is the right address for those looking for high-quality cases that transport equipment reliably and easily. I can highly recommend the cases and bags to any colleague.“

Duncan Shaw



自行车包

BIKE.BAGS

bike.sack



特性 | FEATURES

- 可装自行车的大包
 - 在您坐火车或汽车时可完美地运输您的自行车
 - 坚固的仿尼龙材料制成
 - 内部2个口袋放置轮子
 - 2根拎手带
 - 1根可拆卸和调节的肩带
- big bag for your bike
 - ideal for transporting your bike by train or car
 - made from robust nylon
 - two inside pockets to hold the wheels
 - 2 carrier straps
 - removable and adjustable shoulder strap

规格 | SPECIFICATIONS

内尺寸: 1200x850x230mm | 折叠后的尺寸: 500x250x90mm
重量: 2.15kg | 颜色: 黑色 | 材质: 涤纶

internal dimensions 1200x850x230mm | interfolded 500x250x90mm
weight 2.15kg | color black | material polyester

款号 | ITEM-NO. 96250/N

chain guard



特性 | FEATURES

- 在运输过程中保护链条和变速器，同时避免弄脏其他部件
 - 坚固的仿尼龙面料制成
 - 可以和每一个自行车箱和自行车包共用
- protects chain and rear derailleur during transportation and prevents staining of other parts
 - made from robust nylon
 - can be used with every bike case and bike bag

规格 | SPECIFICATIONS

外尺寸: 610x295mm | 重量: 0.38kg | 颜色: 黑色
材质: 涤纶

external dimensions 610x295mm | weight 0.38kg
color black | material polyester

款号 | ITEM-NO. 96350

轮胎包

WHEEL GUARDS

wheel guard | double wheel guard M/L



特性 | FEATURES

- 带衬垫的轮胎包
 - 采用耐磨的涤纶面料制成
 - 分为单轮胎包和双轮胎包 (配肩带)
 - 有两种尺寸:
中号=28" 及以下轮子
大号= 29" 及以下轮子
 - 3种颜色: 黑色、蓝色、绿色
 - 内部有3个口袋
- padded wheel bag
 - made of durable polyester
 - available as single and double (incl. shoulder strap)
 - two sizes available:
M = for wheels up to 28"
L = for wheels up to 29"
 - three colors: black, blue, green
 - incl. three inward pockets



规格 | SPECIFICATIONS

中号轮胎包
直径: 69cm | diameter 69cm

大号轮胎包
直径: 76cm | diameter 76cm

款号 | ITEM-NO.

96802/black	wheel guard M black	黑色中号轮胎包
96802/blue	wheel guard M blue	蓝色中号轮胎包
96802/green	wheel guard M green	绿色中号轮胎包
96803/black	wheel guard L black	黑色大号轮胎包
96803/blue	wheel guard L blue	蓝色大号轮胎包
96803/green	wheel guard L green	绿色大号轮胎包
96812/black	double wheel guard M black	黑色中号双轮胎包
96812/blue	double wheel guard M blue	蓝色中号双轮胎包
96812/green	double wheel guard M green	绿色中号双轮胎包
96813/black	double wheel guard L black	黑色大号双轮胎包
96813/blue	double wheel guard L blue	蓝色大号双轮胎包
96813/green	double wheel guard L green	绿色大号双轮胎包



以下箱子适用于您的折叠自行车

THE FOLLOWING FOLDING BIKES FIT INTO OUR CASES

	foldon.box S	foldon.box M	foldon.case	foldon.bag
外尺寸(mm) external dimensions (mm)	675 x 710 x 350	865 x 830 x 465	640 x 700 x 330	600 x 600 x 200
内尺寸(mm) internal dimensions (mm)	635 x 620 x 315	815 x 730 x 415	610 x 625 x 240	600 x 600 x 200
重量 (包含配件) weight (kg)	5.4	7.9	7.2	1
折叠自行车 FOLDING BIKES				
Brompton	(可能需要拆座位) (lengthened saddle supports may need to be dismantled)		(可能需要拆座位) (lengthened saddle supports may need to be dismantled)	(可能需要拆座位) (lengthened saddle supports may need to be dismantled)
Riese & Müller	frog	Birdy City, Birdy Dualdrive, Birdy Speed, Birdy Rohloff, World Birdy Comfort, World Birdy Sport		
Dahon	CURL I7, JIFO UNO	EEZZ D3, CURL I7, VITESSE I7, JIFO UNO, CURVE I3 20", CURVE I3 16", SPEED D7, SPEED UNO, CIAO I3, CIAO I7, MARINER D7, VIGOR D9, BOARDWALK D8, ROHLOFF I14	JIFO UNO	JIFO UNO
Tern		LINK D8, LINK D7I, LINK C8, LINK B7, SWOOP D7I, SWOOP DUO, VERGE P20, VERGE P9, VERGE N8		

*截至2018年数据 | Status: June 2018

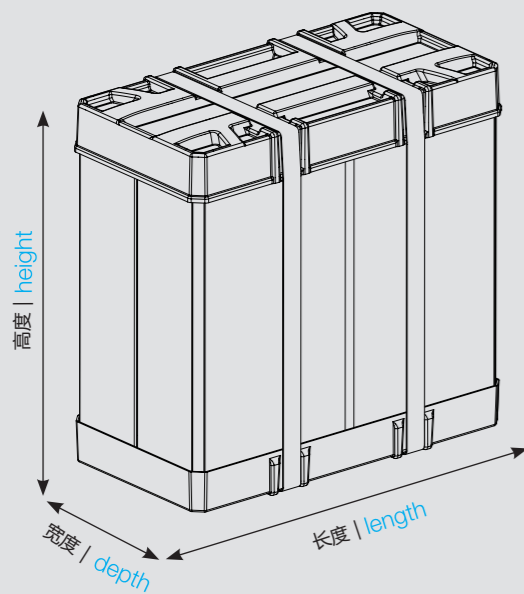

注意：尺寸是基于合拢并且直立的自行车箱或自行车包的长度X宽度X高度。这个表格中的信息仅供参考。具体需要哪款箱子，请根据自行车的实际尺寸对照箱子的内尺寸来选择。

请注意自行车包bike bag跟foldon.box S、foldon.box M和the foldon.case。比较而言，提供的保护较少，对压力和冲击的抵抗比较脆弱。

Note: The dimensions stated are length x height x depth for a closed upright case or closed upright bag. This table only serves the purpose of providing initial orientation. For the actual possibilities of use, please compare the dimensions of your folding bike folded down with the internal dimensions of the case.

Please note that the foldon.bag only offers less protection to your folding bike than the foldon.box S, foldon.box M and the foldon.case.

折叠系列 FOLDON FAMILY

foldon box S | foldon box M

NEW!



特性 | FEATURES

- 折叠自行车的运输箱
 - 有两种尺寸
 - 适用于布朗登和更大的折叠自行车
 - 节约仓储空间-减少体积超过70%
 - 可叠起堆放
 - 4个耐用的轮子易于操作，其中2个万向轮，2个定向轮
 - 带内衬的手把
 - 组装所需时间：不到2分钟
- transport box for folding bikes
 - available in 2 sizes (S/M)
 - suitable for Brompton and bigger folding bikes
 - space-saving storage - volume reduction over 70 %
 - stackable
 - easy handling with four durable wheels, two of them free running, two non-turning
 - padded handles
 - assembly time: less than 2 minutes

FOLDON BOX S

规格 | SPECIFICATIONS

内尺寸：635x620x315mm | 外尺寸：675x710x350mm
折叠之后尺寸：675x210x350mm
重量：5.4kg | 颜色：黑色 | 材质：PP/ABS

internal dimensions 635x620x315mm
external dimensions 675x710x350mm
folded 675x210x350mm | weight 5.4kg
color black | material PP/ABS

款号 | ITEM-NO. 96008

FOLDON BOX M

规格 | SPECIFICATIONS

内尺寸：815x730x415mm | 外尺寸：865x830x465mm
折叠之后尺寸：865x220x465mm
重量：7.9kg | 颜色：黑色 | 材质：PP/ABS

internal dimensions 815x730x415mm
external dimensions 865x830x465mm
folded 865x220x465mm | weight 7.9kg
color black | material PP/ABS

款号 | ITEM-NO. 96010



折叠系列 FOLDON FAMILY

foldon case



特性 | FEATURES

- 适用于布朗登自行车
- 带有拉杆和高品质的轮子, 十分容易操作
- 四周有铝框架保护
- 2把锁
- 箱子外面有根捆绑带
- 也能当行李箱使用
- bike.case with ideal dimensions for Brompton Bikes
- super easy handling through a pull-out telescopic handle and high quality inline wheels
- surrounding aluminum frame with hems protection
- two lockable clip locks
- outward belt embedded in the case
- can also be used as a suitcase

规格 | SPECIFICATIONS

内尺寸: 625x610x240mm
外尺寸: 700x640x330mm
净重: 6.8kg | 颜色: 黑色 | 材质: ABS

internal dimensions 625x610x240mm
external dimensions 700x640x330mm
weight 6.8kg | color black | material ABS

款号 | ITEM-NO. 96006/N



*可选择方向轮版 96011

折叠系列 FOLDON FAMILY

foldon bag



特性 | FEATURES

- 适用于布朗登自行车
- 是一款能与foldon case 和 foldon box相媲美的软包
- 坚固的仿尼龙材料制成
- 配有肩带
- bag for Brompton Bikes
- perfectly fitting bag for the foldon family
- made of tear-proof nylon fabric
- incl. shoulder strap

规格 | SPECIFICATIONS

外尺寸: 600x600x200mm
净重: 1kg | 颜色: 黑色 | 材质: 仿尼龙

external dimensions 600x600x200mm | weight (net) 1kg
color black | material nylon

款号 | ITEM-NO. 96007/N



PHOTO: ©flairimages / Fotolia.com



安全防护箱 OUTDOOR.CASES

你经常能看到：骑行者在骑行或者旅行的时候，将GoPro Action Cam固定在头盔上面，用特殊带子挂在胸前或者挂在自行车把手上面。但是当你的GoPro Action Cam在不用的时候，可以选择我们的GoPro箱子来保护它。坚固、防水和防尘的户外箱可以保护你的照相机不受损坏。

You see it often: mounted on the helmet, with a special strap on the chest or on the handlebars of the bike: the GoPro Action Cam accompanies many cyclists on their runs and tours. To protect your GoPro while it is not being used, you can get our GoPro.cases: robust, waterproof and dustproof outdoor.cases that protect your camera and the necessary accessories against any harms.



type 1000 – GoPro Hero 5



内尺寸: 250 x 175 x 95 mm | 外尺寸: 270 x 215 x 105 mm
容积: 4.1 l | 重量: 0.7kg | 颜色: 黑色、黄色、灰色
配置: 一个GoPro Actioncam及配件的定制海绵内衬

internal dimensions 250 x 175 x 95 mm | external dimensions 270 x 215 x 105 mm | volume 4.1 l | weight 0.7 kg
configuration foam insert for one GoPro Actioncam + accessories
colors black, yellow, grey

款号 | ITEM NO.
1000/B/GoPro5 1000/Y/GoPro5 1000/G/GoPro5

type 3000 – GoPro Hero 5



内尺寸: 330 x 235 x 150 mm | 外尺寸: 365 x 295 x 170 mm
容积: 11.7 L | 重量: 1.9kg | 颜色: 黑色、黄色
配置: 2个GoPro Actioncam及配件的定制海绵内衬

internal dimensions 330 x 235 x 150 mm | external dimensions 365 x 295 x 170 mm | volume 11.7 l | weight 1.9 kg
configuration foam insert for two GoPro Actioncams + accessories
colors black, yellow

款号 | ITEM NO.
3000/B/GoPro5 3000/Y/GoPro5

type 4000 – GoPro Hero 5



内尺寸: 385 x 265 x 165 mm | 外尺寸: 420 x 325 x 180 mm
容积: 16.6 l | 重量: 2.7kg | 颜色: 黑色、黄色
配置: 4个GoPro Actioncam及配件的定制海绵内衬

internal dimensions 385 x 265 x 165 mm | external dimensions 420 x 325 x 180 mm | volume 16.6 l | weight 2.7 kg
configuration foam insert for four GoPro Actioncams + accessories
colors black, yellow

款号 | ITEM NO.
4000/B/GoPro5 4000/Y/GoPro5

工具箱 TOOL.CASES

在一场比赛中，一支队伍的技术员们总是要时刻准备好，以最快的速度拿到所需的工具。

B&W 除了能提供运输自行车的箱子外，还能提供工具箱和工具包，能完美地满足这一需求。

During a race, the technicians of a team must always be ready and have their tools quickly at hand. B&W International offers, next to the bike transport cases, tool cases and bags, which are ideal for this application.

move



内尺寸: 420 x 320 x 90 mm | 外尺寸: 430 x 350 x 230 mm
容积: 12 l | 重量: 2.3 kg | 最大载重量: 12 kg
颜色: 黑色 | 材质: 涤纶

internal dimensions 420 x 320 x 90 mm | external dimensions 430 x 350 x 230 mm | volume 12 l | weight 2.3 kg
max. load 12 kg | colour black | material polyester

款号 | ITEM NO.
116.02 move (16个工具袋+2排松紧带)
move (16 tool pockets + 2 rows loops)

base



内尺寸: 460 x 355 x 180 mm | 外尺寸: 500 x 420 x 200 mm
容积: 29 L | 重量: 5 kg | 最大载重量: 25 kg
可选配置: 工具袋(P), 模角 (M), 松紧带 (L) | 颜色: 黑色 | 材质: ABS

internal dimensions 460 x 355 x 180 mm | external dimensions 500 x 420 x 200 mm | volume 29 l | weight 5 kg
max. load 25 kg | possible configuration pockets (P), loops (L), modules (M) | colour black | material ABS

款号 | ITEM NO.
120.02/P base pockets (37 tool pockets) 工具袋倍译 (37个工具袋)
120.02/M base MODUL (9 Module) 模角倍译 (9块模角)
120.02/L base loops (111 tool loops) 松紧带倍译 (111个松紧带圈)

go



内尺寸: 485 x 370 x 200 mm | 外尺寸: 515 x 445 x 260 mm
容积: 36 l | 重量: 6.8 kg | 最大载重量: 30 kg
可选配置: 工具袋(P), 模角 (M), 松紧带 (L) | 颜色: 黑色 | 材质: ABS

internal dimensions 485 x 370 x 200 mm | external dimensions 515 x 445 x 260 mm | volume 36 l | weight 6.8 kg
max. load 30 kg | possible configuration pockets (P), loops (L), modules (M) | colour black | material ABS

款号 | ITEM NO.
120.04/P go pockets (37 tool pockets) 工具袋吉沃 (37个工具袋)
120.04/M go MODUL (9 Module) 模角吉沃 (9块模角)
120.04/L go loops (111 tool loops) 松紧带吉沃 (111个松紧带圈)

世界各地的倍威 B&W WORLDWIDE



德国 | GERMANY

B&W International GmbH
Junkendiek 5
49479 Ibbenbüren

fon +49 5451 89 46 - 0
fax +49 5451 89 46 444
info@b-w-international.com

西班牙 | SPAIN

B&W Maletas Industriales S.L.
C/de la Ciencia 8
ES-008840 Viladecans (BCN)

fon +34 (0) 93 647 64 84
fax +34 (0) 93 647 64 83
comercial@kitther.com

北美 | NORTH AMERICA

B&W North America
12200 Farmington Rd.
Livonia, MI 48150 (USA)

fon +1 (0) 734 7 44 55 66
fax +1 (0) 734 7 44 55 68
contact@b-w-international.com

印度 | INDIA

B&W International India

fon +91 (0) 989 11 140 05
rajeev.kaushik@b-w-international.com

中国 | CHINA

倍威实业(嘉兴)有限公司
浙江省嘉兴市经济技术开发区丰华路997号

fon +86 (0) 573 8269 3528
fax +86 (0) 573 8269 3530
info@b-w-international.com.cn